

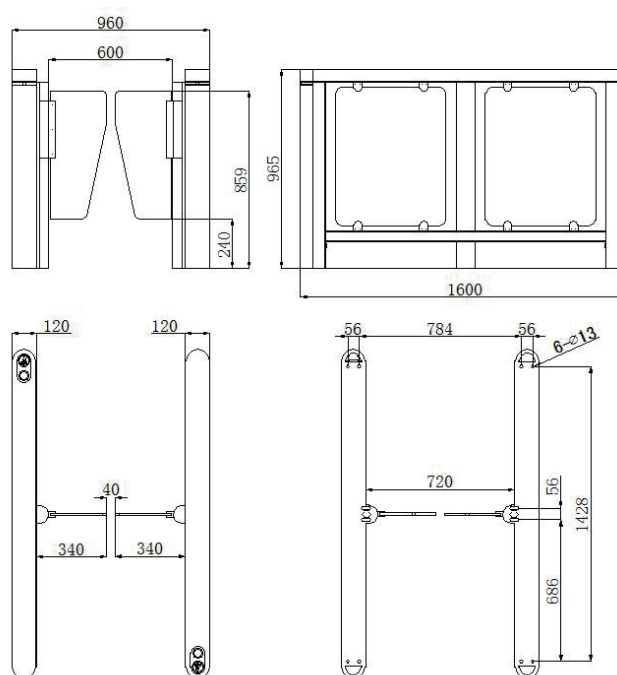

Technical parameter

Power supply: AC220V±10%V 50HZ.
Power consumption: static power consumption < 30W, dynamic power consumption < 70W
Motor power: 40W(brushless motor)
IP protection level: 42
Infrared quantity: 6 pairs infrared
Communication interface: switch value, optional RS232/RS485
Channel width: 600mm ~ 900mm
Door opening speed:0.6s
Number of passers: 30 ~ 40/min
Working environment: indoor and outdoor (outdoor plus rain shed)-25°C ~ 70°C
Relative humidity≤90%, no condensation
Gate opening signal: 100 low level or passive contact signal not less than 100
Chassis material: standard 304 stainless steel. thickness:1.2mm ~ 3.0mm



* The appearance of the chassis can be customized according to requirements