

CWKM01

4 fences barrier gate

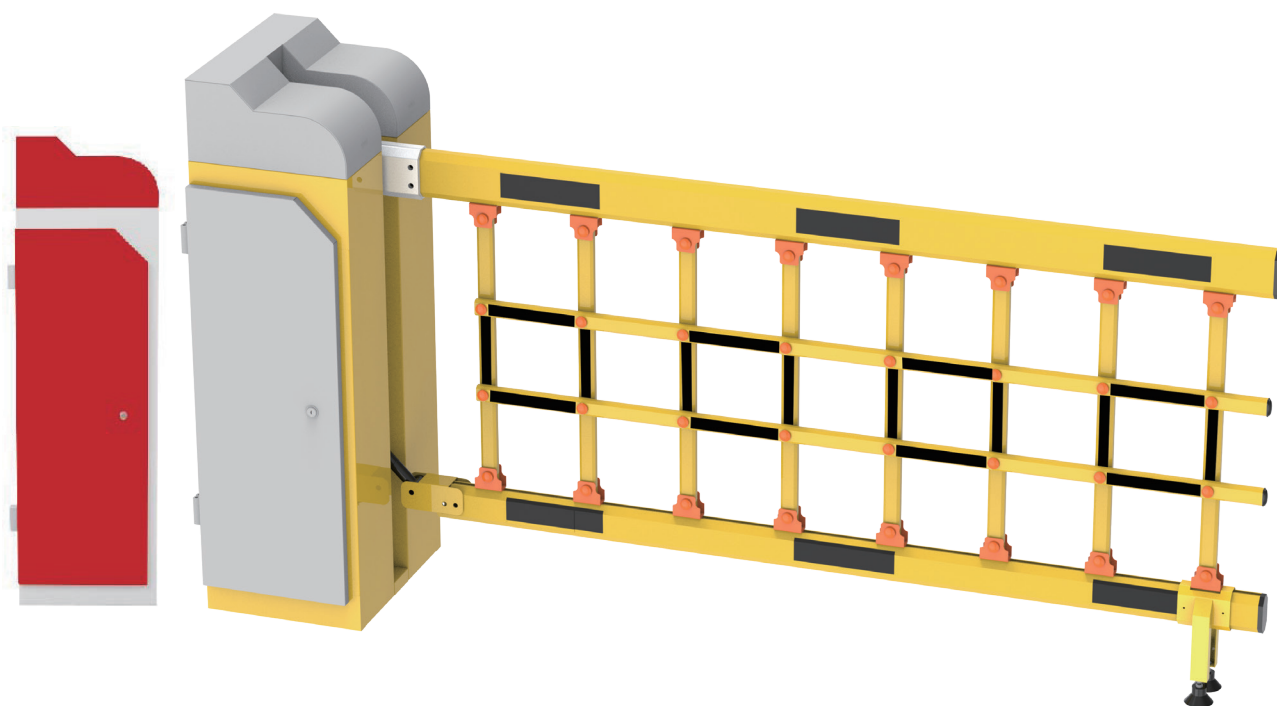

Technical parameter

Power supply: AC220V±10%V, 50HZ.

Power consumption: static power consumption < 70W,
dynamic power consumption < 150W

working environment: -25°C ~ 70°C

Relative humidity: ≤90%, no condensation

Equipped with pole length: ≤6m two railings
≤6m four railings

Motor: AB phase motor, two-stage variable speed

Motor Power: 150W

lift time:6s

Optional pole category: airborne gate and two fence

